

**Single switch
Trench IGBT® Power Module**

**$V_{CES} = 1200V$
 $I_C = 600A @ T_c = 80^\circ C$**

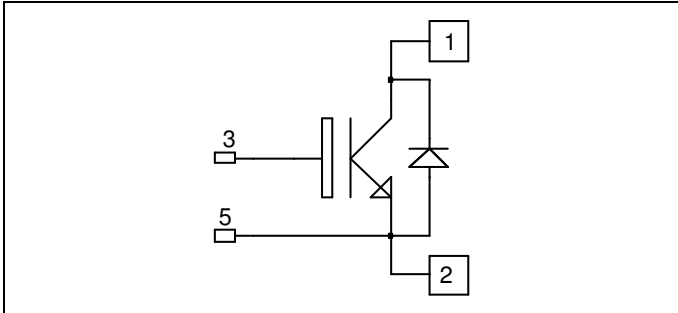

Application

- Welding converters
- Switched Mode Power Supplies
- Uninterruptible Power Supplies
- Motor control

Features

- Trench + Field Stop IGBT® Technology
 - Low voltage drop
 - Low tail current
 - Switching frequency up to 20 kHz
 - Soft recovery parallel diodes
 - Low diode VF
 - Low leakage current
 - Avalanche energy rated
 - RBSOA and SCSOA rated
- Kelvin emitter for easy drive
- Low stray inductance
 - M6 connectors for power
 - M4 connectors for signal
- High level of integration

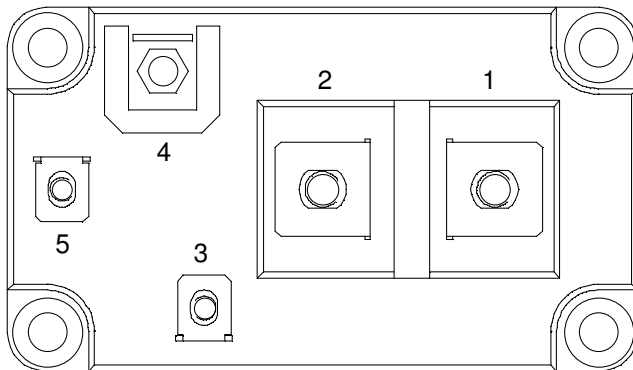

Benefits

- Outstanding performance at high frequency operation
- Stable temperature behavior
- Very rugged
- Direct mounting to heatsink (isolated package)
- Low junction to case thermal resistance
- Easy paralleling due to positive TC of VCEsat

Absolute maximum ratings

Symbol	Parameter	Max ratings	Unit
V_{CES}	Collector - Emitter Breakdown Voltage	1200	V
I_C	Continuous Collector Current	$T_C = 25^\circ C$	880
		$T_C = 80^\circ C$	600
I_{CM}	Pulsed Collector Current	$T_C = 25^\circ C$	1500
V_{GE}	Gate - Emitter Voltage	± 20	V
P_D	Maximum Power Dissipation	$T_C = 25^\circ C$	2500
SCSOA	Short Circuit Safe Operating Area	$T_j = 125^\circ C$	2000A@900V

CAUTION: These Devices are sensitive to Electrostatic Discharge. Proper Handling Procedures Should Be Followed.

All ratings @ $T_j = 25^\circ\text{C}$ unless otherwise specified

Electrical Characteristics

Symbol	Characteristic	Test Conditions	Min	Typ	Max	Unit
BV_{CES}	Collector - Emitter Breakdown Voltage	$V_{GE} = 0V, I_C = 24mA$	1200			V
I_{CES}	Zero Gate Voltage Collector Current	$V_{GE} = 0V, V_{CE} = 1200V$			16	mA
$V_{CE(on)}$	Collector Emitter on Voltage	$V_{GE} = 15V$ $I_C = 600A$		$T_j = 25^\circ\text{C}$ $T_j = 125^\circ\text{C}$	1.7 2.1	V
$V_{GE(th)}$	Gate Threshold Voltage	$V_{GE} = V_{CE}, I_C = 24mA$	5.0	5.8	6.5	V
I_{GES}	Gate - Emitter Leakage Current	$V_{GE} = 20V, V_{CE} = 0V$			1200	nA

Dynamic Characteristics

Symbol	Characteristic	Test Conditions	Min	Typ	Max	Unit
C_{ies}	Input Capacitance	$V_{GE} = 0V$		40		nF
C_{oes}	Output Capacitance	$V_{CE} = 25V$		2.4		
C_{res}	Reverse Transfer Capacitance	$f = 1MHz$		2		
$T_{d(on)}$	Turn-on Delay Time	Inductive Switching (25°C)		250		ns
T_r	Rise Time	$V_{GE} = \pm 15V$		90		
$T_{d(off)}$	Turn-off Delay Time	$V_{Bus} = 600V$ $I_C = 600A$		550		
T_f	Fall Time	$R_G = 1.1\Omega$		130		
$T_{d(on)}$	Turn-on Delay Time	Inductive Switching (125°C)		300		ns
T_r	Rise Time	$V_{GE} = \pm 15V$		100		
$T_{d(off)}$	Turn-off Delay Time	$V_{Bus} = 600V$ $I_C = 600A$		650		
T_f	Fall Time	$R_G = 1.1\Omega$		180		

Reverse diode ratings and characteristics

Symbol	Characteristic	Test Conditions	Min	Typ	Max	Unit
V_F	Diode Forward Voltage	$I_F = 600A$ $V_{GE} = 0V$		$T_j = 25^\circ\text{C}$ $T_j = 125^\circ\text{C}$	1.6 1.6	2.1 V
E_{rec}	Reverse Recovery Energy	$I_F = 600A$ $V_R = 600V$ $di/dt = 900A/\mu s$		$T_j = 125^\circ\text{C}$	48	mJ
Q_{rr}	Reverse Recovery Charge	$I_F = 600A$ $V_R = 600V$ $di/dt = 900A/\mu s$		$T_j = 25^\circ\text{C}$ $T_j = 125^\circ\text{C}$	56 112	μC

Thermal and package characteristics

Symbol	Characteristic	Min	Typ	Max	Unit
R_{thJC}	Junction to Case	IGBT		0.05	$^\circ\text{C/W}$
		Diode		0.075	
V_{ISOL}	RMS Isolation Voltage, any terminal to case $t = 1$ min, $I_{isol} < 1mA, 50/60Hz$	2500			V
T_j	Operating junction temperature range	-40		150	$^\circ\text{C}$
T_{STG}	Storage Temperature Range	-40		125	
T_C	Operating Case Temperature	-40		125	
Torque	Mounting torque	M6	3	5	N.m
		M4	1	2	
Wt	Package Weight			420	g

Package outline

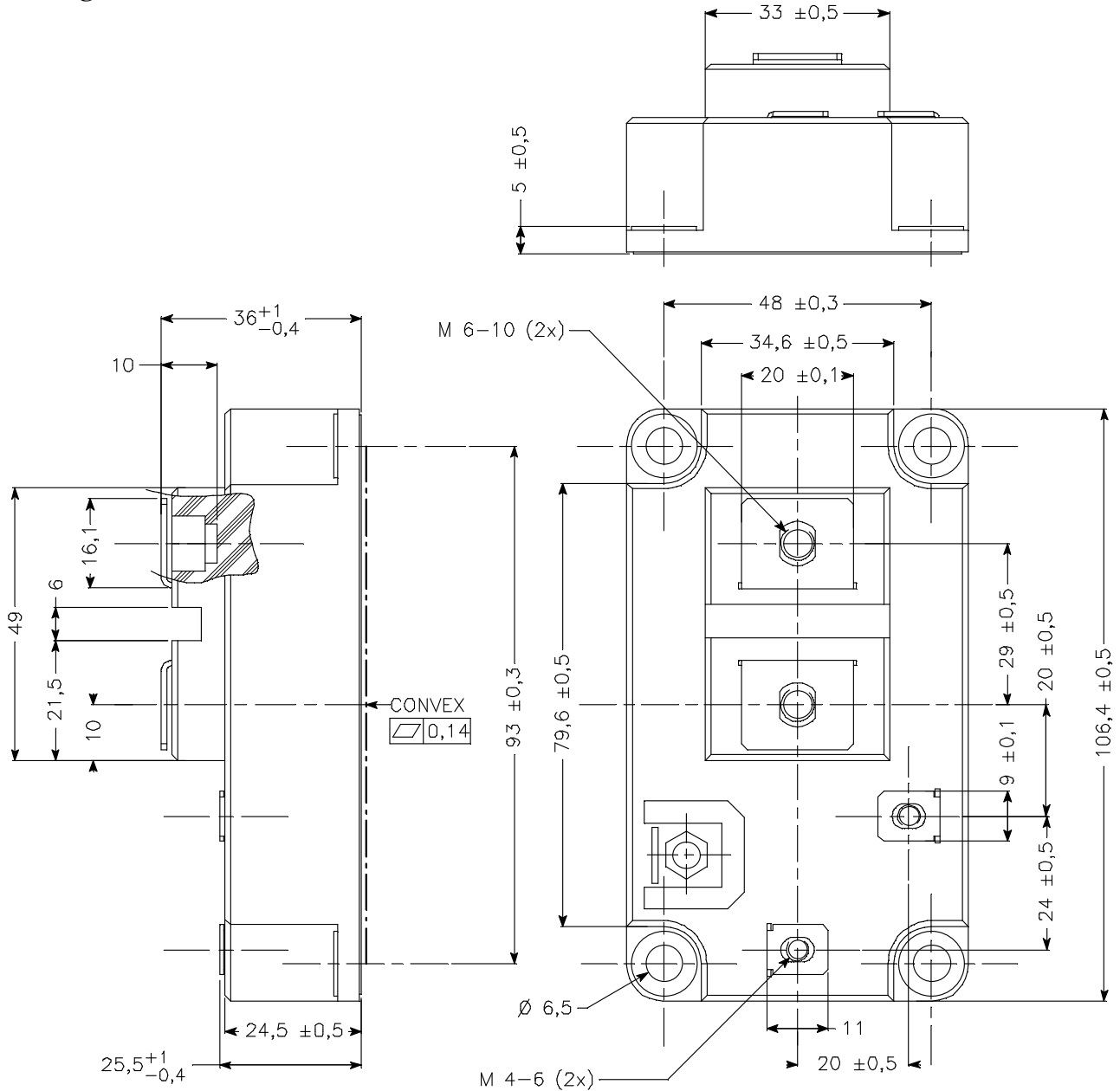

APT reserves the right to change, without notice, the specifications and information contained herein

APT's products are covered by one or more of U.S. patents 4,895,810 5,045,903 5,089,434 5,182,234 5,019,522 5,262,336 6,503,786 5,256,583 4,748,103 5,283,202 5,231,474 5,434,095 5,528,058 and foreign patents. U.S. and Foreign patents pending. All Rights Reserved.